

# 427-CS27E LiftFlex CPU-Holder

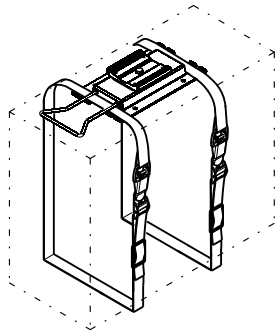

**Before assembly**  
Please spend some times to read this and follow the procedures step by step.  
Some panels are viewed differently from the exploded drawing below. This is for extra clarity. Do not discard any of the packaging until you have checked all the parts and the package of fittings. If you are missing any of the parts, please contact the store from which you purchased your products. The staff will do their best to help you.

## Parts Check-List

- 01** Slide Support X1
- 02** Beltlock X2

## Fitting Check-List

- 03** Screw X4
- 04** Additional pads X4

**1** 4 pcs screws to secure the holder under the desk.

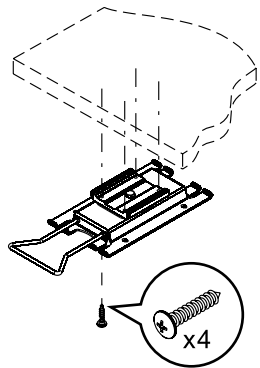

**2** Please check 4 pcs of stoppers under the convex plate corner in order to protect the CPU (as figure).

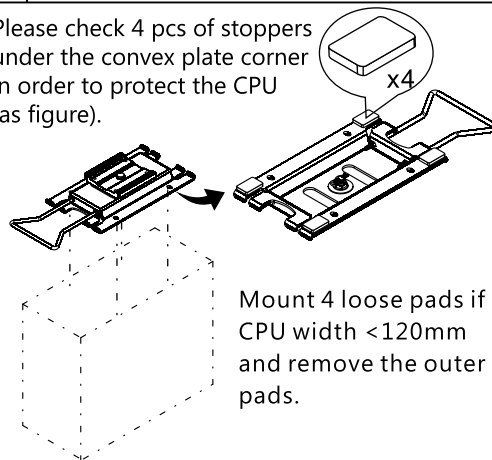

## Caution:

Regular cleaning with a clean dry cloth is usually sufficient, but for stubborn marks, wipe over gently with a clean damp cloth. Never use strong detergents or abrasive cleaners as these may damage the surface finish of your furniture. There are many small components used in the construction of this unit. These loose items should be kept away from young children while assembling your unit.

Patent Pending

20140606 (E-C)

# Assembly Guide

**3** Place the CPU on the floor and align the beltlock straps around it. Position the slider plate on top (align center/middle) and align the strap on the strap member (as illustrated).

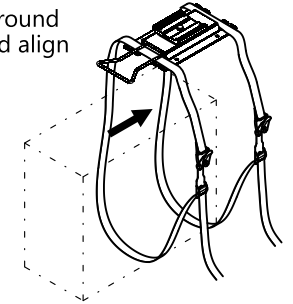
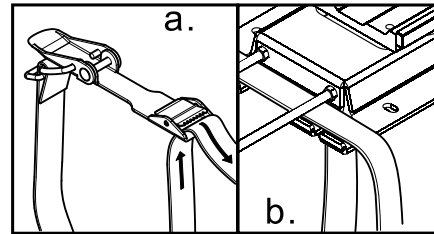

**4** Adjust the length of the rope for CPU, the method as following:  
1. Pull down one of the rope first and then another rope.  
2. Repeat step 1, until the top of the CPU touches the stoppers.  
3. Press down the beltlock cover (see figure right) in order to fit the CPU properly and avoid the rope loose.  
4. Piercing through the top of the hoop of the beltlock with the remaining rope and the rope won't hang down to the ground. (see figure right)

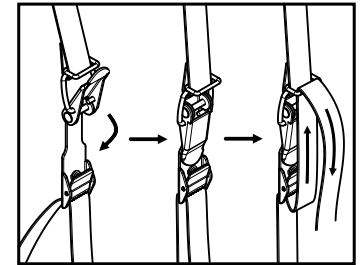

## Note:

- \* Do not move over-high when supporting a CPU.
- \* Supporting the CPU during the whole adjustment.

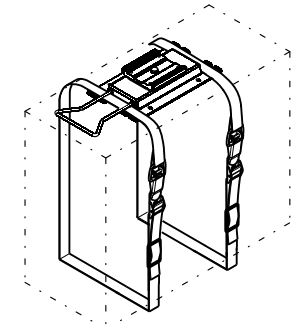

## Additional Accessories

**Sliding Rail**  
Part no 430-WA11, 400 mm  
Part no 430-WA13, 300 mm  
Part no 430-WA16, 600 mm

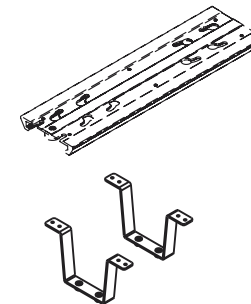

**Desk distance +65mm**  
Part no 427-CS08

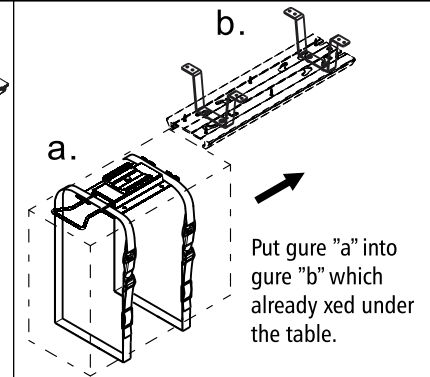

# 427-CS27E LiftFlex CPU-hållare

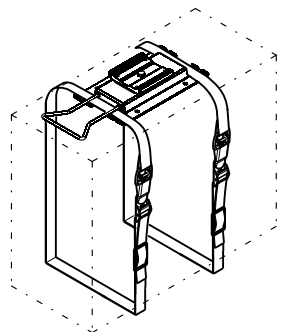

Tack för att Ni valt en produkt från Kondator  
Ägna gärna några minuter att läsa denna monteringsanvisning.  
Detta är ett steg för steg underlätta monteringen.  
Bifogat finns en lista på de tillbehör som skall finnas med i paketet. Kontrollera noga innehållet före montering !

## Innehåll

01 CPU-Hållare & skena X1

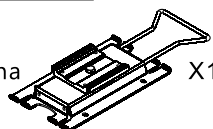

02 Spännband X2

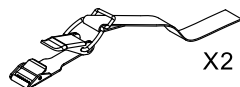

## Övriga detaljer

03 Skruv X4



04 Extra friktionsbelägg X4

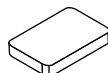

1 4 st skruvar för säker montering under bordsskiva.

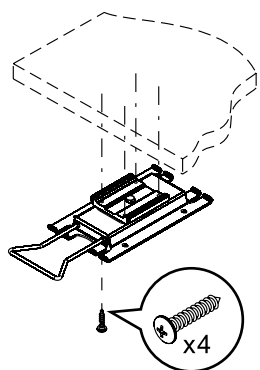

2 Montera vid behov de löst bifogade friktionsbelägg 04 på de inre remhakarna om datorns bredd är mindre än 120 mm (avlägsna de yttre Friktionsbelägg).

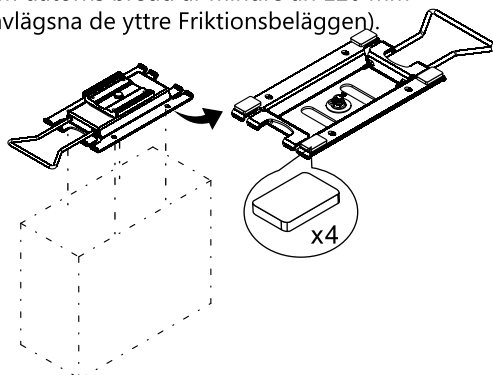

Artnr 427-CS27E  
Rekommendationer:  
Rengör regelbundet med en ren trasa.  
Använd aldrig starka lösningsmedel.

Patent Pending

*Kondator*  
www.kondator.se

# Monteringsanvisning

3 Placera datorn på golvet och dra spännbanden runt datorn. Placera släden mitt på datorhöljets ovansida och lägg spännbandet runt remhakarna.

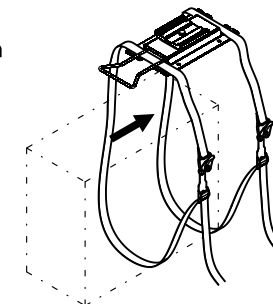
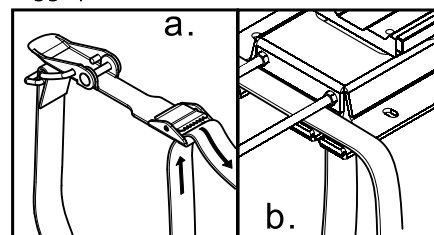

4 Anvisningar för justering av spännbanden:  
1. Drag åt båda spännbanden (02)  
2. Upprepa enl ovan tills datorn ovansida ligger stadigt mot friktionsbelägen /upphängningsblecken.  
3. Justera och stoppa in "överblivet spännband" i där avsedd ring.  
4. Pressa därefter ned spännet på låset.  
Detta säkerställer datorns position i spännbanden.

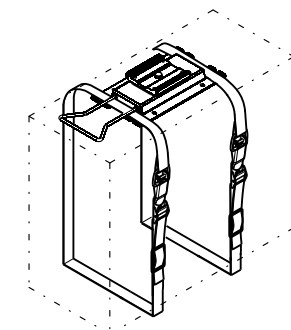
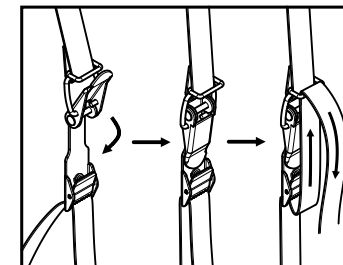

## Extra tillbehör

### Skena

Art nr 430-WA11, 400 mm  
Art nr 430-WA13, 300 mm  
Art nr 430-WA16, 600 mm

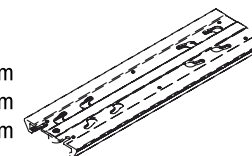

Bordsdistans +65mm  
Art nr 427-CS08

